



FICHE TECHNIQUE

FA 50 214 60

Désignation : Mousqueton aluminium à verrouillage automatique double action avec linguet

Matière : Alliage d'aluminium.

Ouverture : 60 mm.

Résistance : 20 kN.

Conformité : EN362 : 2004 Classe A et T.

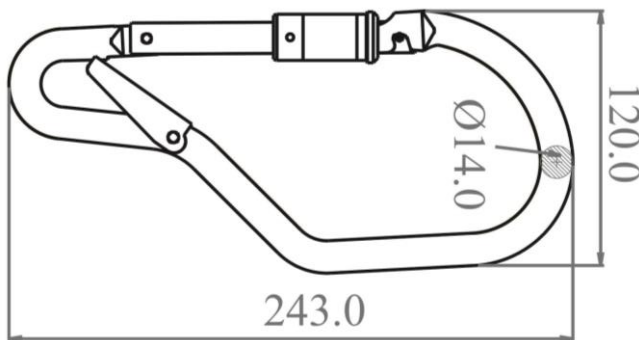

HS code

76161000

Dimension carton / UC

40 x 30 x 20 / 50

Poids unitaire

0.24 Kg

AET : N° 5840 Issue 1 Extension 2

Satra Technology Centre, N°0321
Wyndham Way, Telford Way, Kettering,
Northamptonshire, NN16 8SD, United Kingdom.

Article 11: GB07/73551

SGS United Kingdom Ltd., N° 0120
Unit 202B, Worle Parkway,
Weston-super-Mare, BS22 6WA, United Kingdom



MAJ : 12/14

ZI les portes du Dauphiné

4 rue de l'Aigue

69 780 St Pierre de Chandieu – France

Tel : +33 (0)4 72 48 78 27 Fax : + 33 (0)4 72 48 58 32

www.kratossafety.com info@kratossafety.com

