



FICHE TECHNIQUE

FA 50 209 14

Désignation :

Crochet d'amarrage inox double action

Matière : Acier inoxydable

Ouverture : 140 mm

Résistance : 23 kN

Conformité : EN362 : 2004 Classe A

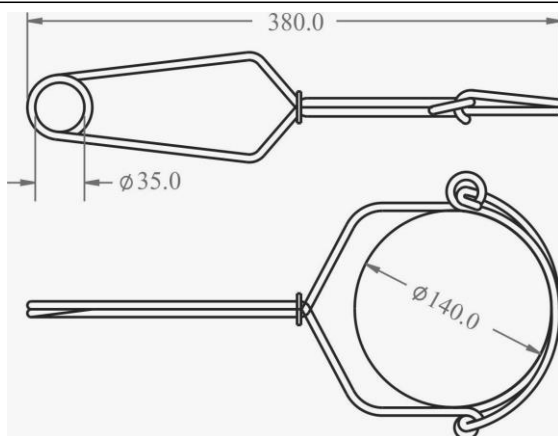

HS code

83081010

Dimension carton/ UC

66x38x24 / 25

Poids unitaire

0,37 kg

AET : N° 2597 Issue 1 Extension 6

Satra Technology Centre, N°0321
Wyndham Way, Telford Way, Kettering,
Northamptonshire, NN16 8SD, United Kingdom.

Article 11 : GB07/73551

SGS United Kingdom Ltd., N° 0120
Unit 202B, Worle Parkway,
Weston-super-Mare, BS22 6WA, United Kingdom



maj : 05/11

ZI les portes du Dauphiné

4 rue de l'Aigue

69 780 St Pierre de Chandieu – France

Tel : +33 (0)4 72 48 78 27 Fax : + 33 (0)4 72 48 58 32

www.kratossafety.com info@kratossafety.com

